

# 7 SIMPLE SCIENCE EXPERIMENTS FOR YOUR CLASSROOM

## READY TO TAKE THE SCIENCE IN YOUR CLASSROOM TO THE NEXT LEVEL?

Covering students aged 6-11 years, our classroom experiments are hands-on, informative, fun and designed to support your curriculum objectives, making them the perfect addition to your science lessons!

### HOW DO I USE THIS DOCUMENT?

1. Print the appropriate classroom experiment for your class.
2. Collect the necessary materials (don't worry, they are all easy to source!).
3. Get your students learning – hands-on!
4. Finish off with the discussion questions.

**stemscopes**  
**SCIENCE**

 A 3P Learning product.



# TABLE OF CONTENTS

Exploring the power of wind (Ages 6 - 7 years)	4
Exploring the effect of colour on heat (Ages 7 - 9 years)	6
Exploring friction in the air (Ages 8 - 9 years)	8
Exploring unexpected forces (Ages 8 - 10 years)	10
Exploring the effect of heat on liquids and gases (Ages 9 - 10 years)	12
Exploring how different liquids mix together (Ages 9 - 10 years)	14
Exploring chemical changes to material (Ages 9 - 10 years)	16
Soap speeder template	18

# AGES: 6 - 7 YEARS

## EXPLORING THE POWER OF WIND

### THE BALLOON-POWERED CAR

Forget about batteries, petrol or pedals! Build a car that literally runs on hot (is it hot?) air. Here's how you can build your very own balloon-powered car and become an environmentally-friendly speedster.

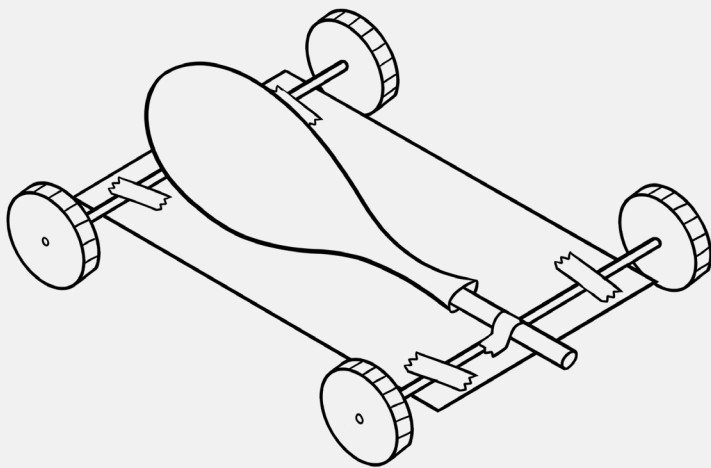

#### WHAT DO YOU NEED?

- Rectangular piece of cardboard 30 cm long and 15cm wide
- Wooden kebab skewers
- 4 plastic bottle caps
- A straw
- A balloon
- Tape
- Nails
- Scissors
- Hammer
- Knife

#### FUN FACT!

Wind-powered cars are real – but not very reliable. They need another source of energy to start before the wind can move them.

### THE BALLOON-POWERED CAR

#### PROCEDURE

1. Cut the straw into 2 pieces.
2. Use tape to attach the straws to the cardboard, one in the front and one in the back (line them up carefully as they will act as the car's axles).
3. Use the hammer and nails to poke small holes in the centre of the bottle caps.
4. Cut 2 kebab skewers to be approximately 4 cm longer than the pieces of straw attached to the cardboard.
5. Put one end of the cut kebab skewer into the hole in the bottle caps.
6. Put the skewer through the straws attached to the cardboard.
7. Then place the other end of the skewer into the hole of the bottle cap on the other end (make sure they roll cleanly and if so repeat process for the other straw axle).
8. Tape the 4 straws together.
9. Place the taped straws into the mouth of the balloon and tape together.
10. Tape straws to cardboard with the blowing section facing the rear.
11. Leave 2-3cm of nozzle sticking out the mouth.
12. Find a long flat surface.
13. Blow up the balloon through the nozzle.
14. Pinch the balloon closed from blowing through the nozzle.
15. Place on the cardboard and let it go.

## DISCUSSION QUESTIONS:

1. Can you think of something you could create that would work under water in the same way?
  2. The balloon car is wind-powered. Can you think of any other things you know that are wind-powered?
  3. Why does the balloon car keep moving a little bit further once all the air has gone from the balloon?
- 

## WHAT HAPPENS?

When you stop pinching the balloon the air is free to rush out through the nozzle. This air pushes against the air behind the car and propels the balloon car forward.

Customise your car and race your friends to prove who has the fastest lung-powered ride.

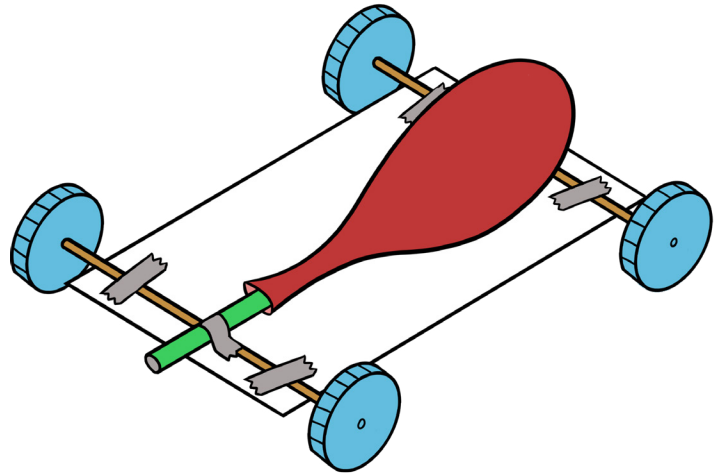

# AGES: 8 - 9 YEARS

## EXPLORING THE EFFECT OF COLOUR ON HEAT

### COLOUR ME RED HOT

Colours aren't just pretty - they can also absorb or reflect light and turn light into heat. But which colours absorb or reflect more light? Let's find out!

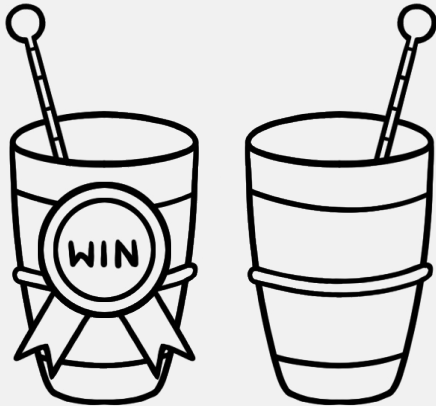

#### WHAT DO YOU NEED?

- 2 glasses of water
- 2 rubber bands
- Black paper
- White paper
- Thermometer

#### FUN FACT!

Did you know that white light reflects ALL the colours of the rainbow?

### COLOUR ME RED HOT

#### PROCEDURE

1. Cover the outside of one glass with white paper and the other with black.
2. Secure the paper with rubber bands.
3. Fill the glasses with equal amounts of water.
4. Sit the glasses in the sunlight.
5. Use a thermometer to measure the temperature of the water every 5 minutes for up to an hour.
6. Record the results.

#### DISCUSSION QUESTIONS:

1. Why do so many people in hot climates buy white cars?
2. Have you ever noticed that black objects or surfaces can become very hot? Have you ever walked on a black road in bare feet? Ouch! How could this knowledge about dark colours help with the design of buildings, sports fields or playgrounds?
3. Why is the background of a solar panel usually covered in black material?

# WHAT HAPPENS?

The water in the glass with black paper will have a higher temperature than the water in the glass with the white paper. Why? Because dark-coloured surfaces absorb more light and convert it to heat; whereas light coloured surfaces reflect more light and therefore are cooler. Try this experiment with your favourite colours and discover if you're a hot head or a cool cucumber.

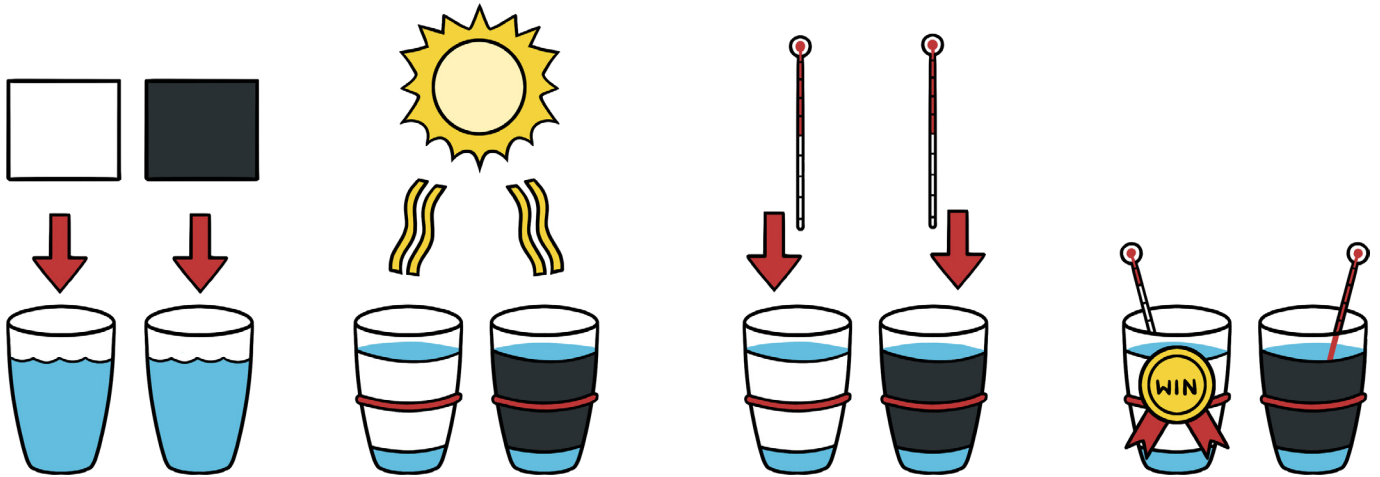

# AGES: 8 - 9 YEARS

## EXPLORING FRICTION IN THE AIR

### THE HOOP GLIDER

Everybody has a favourite paper aeroplane design. Some are sharp and sleek and fly in a perfectly straight line; some are wide and float around the room in giant loops; and others just fall at your feet! The greatest inventors try to think a bit differently to everyone else. Try something completely different with this 'paper plane' design using hoops of paper and a straw!

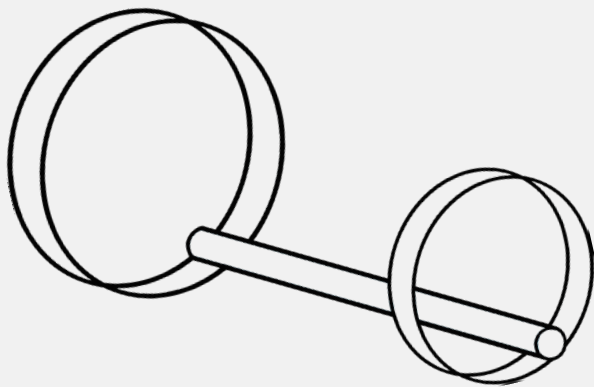

#### WHAT DO YOU NEED?

- A plastic straw
- 7.5 x 13 cm piece of stiff paper
- Tape
- Scissors

#### FUN FACT!

Did you know that objects of different weight tend to fall to the ground at the same speed if there is no air resistance? That's why the heavier paper doesn't flip the glider upside down!

### THE HOOP GLIDER

#### PROCEDURE

1. Cut the stiff paper into 3 separate pieces measuring 2.5 cm x 13 cm.
2. Tape 2 of the pieces together to form a large hoop shape.
3. Use the last strip of stiff paper to make a smaller hoop.
4. Tape the paper loops to both ends of the straw.
5. Grasp from the centre of the straw and throw in a slightly upward angle with the smaller hoop at the front.

#### DISCUSSION QUESTIONS:

1. Does the position of the hoops on the straw affect the results? How?
2. Does a bigger hoop glider fly further?
3. Why does a screwed-up piece of paper fall to the ground faster than a sheet of paper?

## WHAT HAPPENS?

The same four forces that help an aeroplane fly are acting on the hoop glider (thrust, drag, lift and weight). You create thrust when you throw the hoop glider. The hoop glider will fly in a long straight motion due to the curved shape of the large hoop acting like a wing and creating lift (the force that keeps the plane in the air), while the smaller hoop keeps the plane on a straight course. The large hoop also creates drag (the force that slows objects down) and the weight of the glider pulls it back down to the ground. Hoop gliders usually have less drag than paper planes as they have rings rather than wings!

Your new age flying contraption will turn the original paper plane into the dinosaur of class-built entertainment.

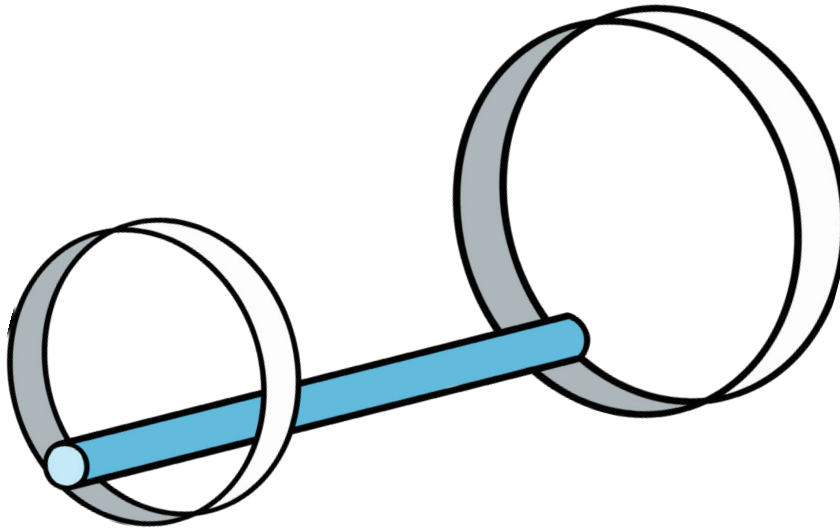

# AGES: 8 - 10 YEARS

## EXPLORING UNEXPECTED FORCES

### THE SOAP SPEEDER

Master the seven seas, or a small surface of water with your very own soap-powered boat!

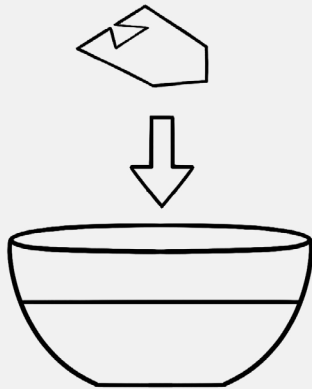

#### WHAT DO YOU NEED?

- A thin foam tray or a piece of non-corrugated cardboard
- A tray, bowl, or cookie sheet full of water
- Liquid soap
- A toothpick

#### FUN FACT!

Small insects such as the water strider can walk on water because their weight is not enough to penetrate the surface.

### THE SOAP SPEEDER

#### PROCEDURE

1. Cut the thin foam or cardboard into a boat shape. Aim for a boat size of around 5 cm. **Alternatively**, print out our template (see page 18), stick it on the **outside** of your foam or cardboard and cut it out.
2. Dip a toothpick into the liquid soap.
3. Dab the soap lathered toothpick onto the cut-out section on the back of the boat.
4. Gently place the boat in the tray of water and look at it go!

*Note: Rinse the tray out of soapy water to perform the experiment again.*

#### DISCUSSION QUESTIONS:

1. Does it work any differently when you change the temperature of the water?
2. What happens if you put soap at both the front and back of the boat?
3. If you sprinkled pepper over the surface of a dish of water then dipped a finger covered in detergent in the centre of the water, what do you think you would see happen to the pepper?

## WHAT HAPPENS?

Water molecules are strongly attracted to each other and stick close together creating 'surface tension'. The liquid soap acts as a surfactant (breaks down the surface tension of water). Once the soapy section of the boat comes into contact with the water, the breakdown of the surface tension builds enough force to push the boat across the water. Challenge your classmates to a boat off with the winner claiming the prize of most well-built soap-covered piece of scientific wonder.

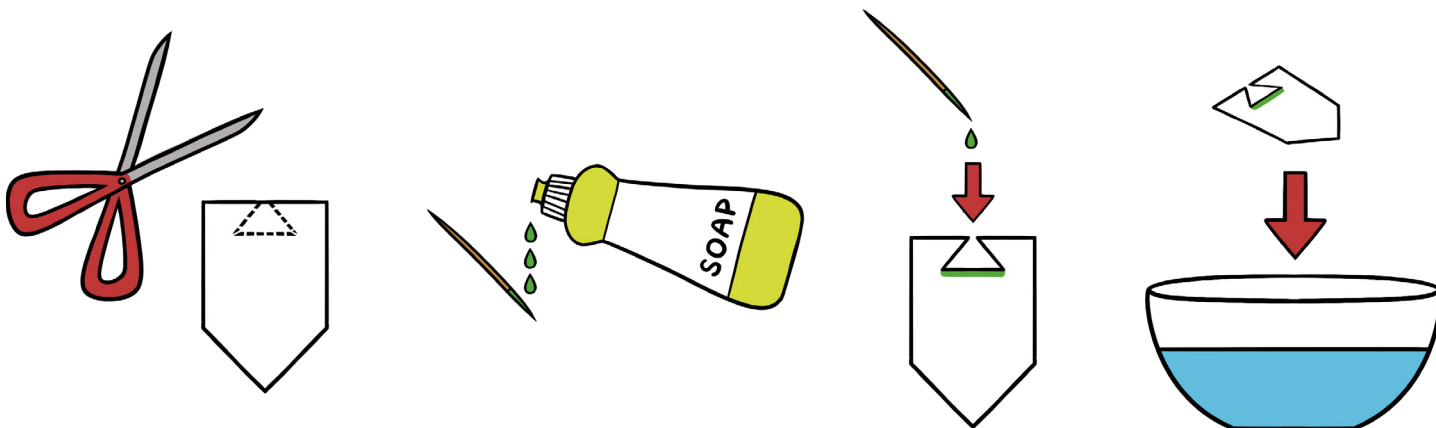

# AGES: 9 - 10 YEARS

## EXPLORING THE EFFECT OF HEAT ON LIQUIDS AND GASES

### CLOUD IN A CUP

Did you know that there is a fixed amount of water on Earth? It's continually moving through 'the water cycle'. The cycling of water on Earth affects our weather patterns including the amount of rain we get - but have you ever wondered how the rain gets into the clouds in the first place?



#### WHAT DO YOU NEED?

- A jar with a lid
- 50mL of boiling water
- Ice cubes
- An aerosol can (e.g. deodorant, hairspray)

#### FUN FACT!

The ocean holds 97% of the total water on the planet.

### CLOUD IN A CUP

#### PROCEDURE

1. Take the lid off the jar.
2. Pour the hot water into the jar.
3. Swirl the water so the jar's surface warms up.
4. Turn the lid upside down and place ice cubes into the lid.
5. Rest the lid with the ice cubes on the top of the jar.
6. Using a quick action, slide the lid off briefly and spray in some of the aerosol, then place the lid back on.
7. Watch the cloud start developing within the jar.
8. When the cloud has consumed the jar, remove the lid.

#### DISCUSSION QUESTIONS:

1. Where else have you seen water vapour return to liquid form?
2. How long do you think it would take a cup of water to evaporate? What could speed up or slow down the time it takes to evaporate?
3. Why might there be more rain in a warm, humid environment?

## WHAT HAPPENS?

Clouds in the atmosphere form when moist warm air containing water vapour (gaseous water) rises and meets cooler air, causing the water vapour to condense back into droplets of water and attach to small particles in the air such as dust (called cloud condensation nuclei). If enough water droplets clump together and become heavy enough, it will rain. In this experiment, trapping the hot water in the jar creates warm moist air. The warm moist air rises inside the jar until it reaches the cooler air at the top of the jar and begins to cool. When the water vapour cools, it wants to turn back into liquid, but it needs to condense onto a surface. The aerosol provides small particles that act like dust in the atmosphere and help the water vapour turn back into tiny water droplets. The continuous action of warm air rising, and cool air sinking causes the cloud to swirl.

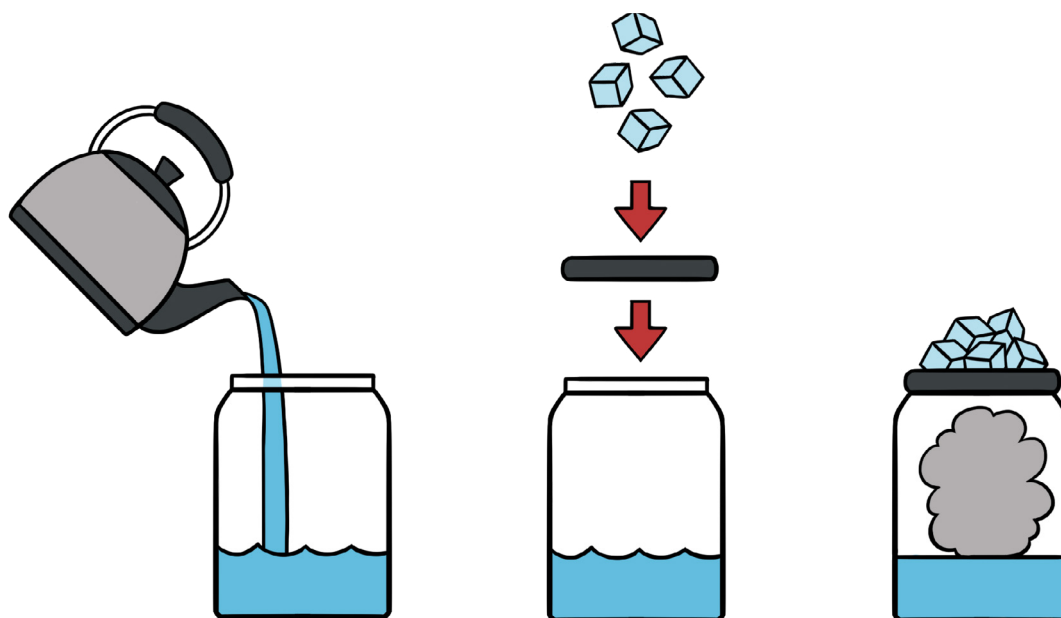

# AGES: 10 – 11 YEARS

## EXPLORING HOW DIFFERENT LIQUIDS MIX TOGETHER

### ALL BOTTLED UP

Colours aren't just pretty - they can also absorb or reflect light and turn light into heat. But which colours absorb or reflect more light? Let's find out!

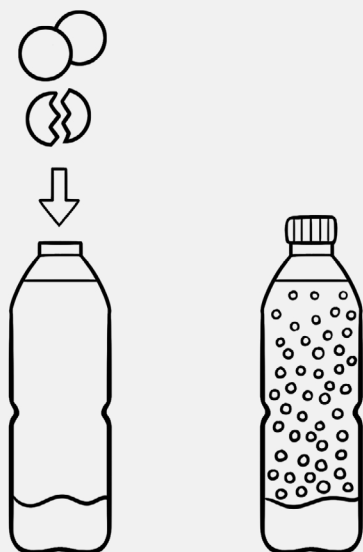

#### WHAT DO YOU NEED?

- A 1L bottle
- Vegetable oil
- $\frac{3}{4}$  cup or 180ml of water
- Fizzing tablets
- Food colouring of your choosing

#### FUN FACT!

We use detergents and soaps to clean ourselves, our clothes and other objects as detergents are attracted to BOTH water and oil at the same time.

### ALL BOTTLED UP

#### PROCEDURE

1. Pour water into the bottle.
2. Slowly funnel the vegetable oil into bottle until it is close to being full.
3. Wait for the water and oil to separate.
4. Add up to 10 drops of food colouring.
5. Drop half a fizzy tablet into the bottle and put on the lid.

#### DISCUSSION QUESTIONS:

1. Mixing oil and water creates a reversible physical change. The two substances don't chemically change. What other substances can you mix together that don't chemically change?
2. If you placed the cap on the bottle with small holes in it to let some air out, would it take longer for the fizzes to run out?
3. Do you think air is lighter or heavier than water or oil? Why? Why not?

## WHAT HAPPENS?

The oil stays above the water as it is lighter and won't mix because of intermolecular polarity (water molecules attract to water molecules and oil molecules attract to oil molecules but neither can mix with each other). When the fizzy tablets are added it creates rising air bubbles which catch the food colouring upon rising and then when the gas reaches the top it releases, and the coloured bubbles go back down. Keep the fizzing fun going by adding more tablets when all the air releases and show everyone your interactive interior design skills

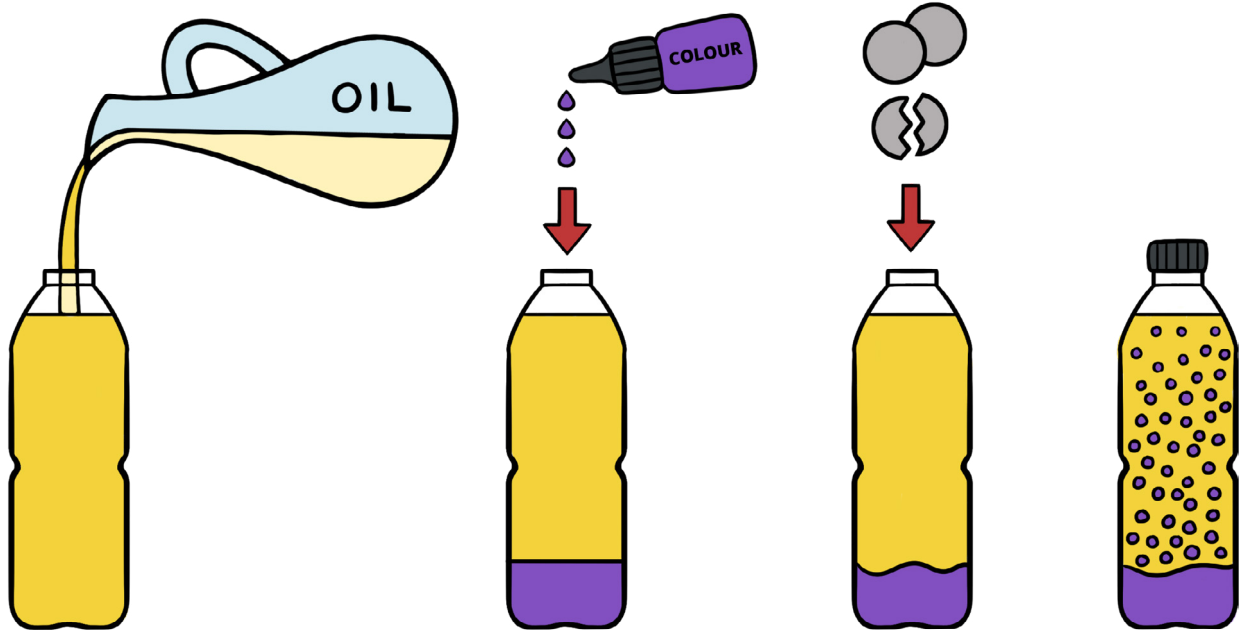

# AGES: 10 - 11 YEARS

## EXPLORING CHEMICAL CHANGES TO MATERIALS

### COIN CLEANER

Have you ever looked in your wallet and thought 'why are my coins so old and rusty?' Through the magic of science we can make that old change look shiny and new again!

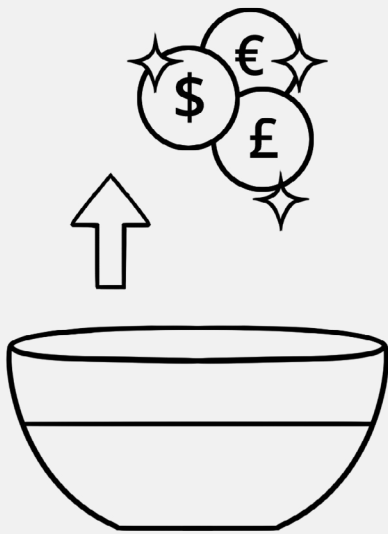

#### WHAT DO YOU NEED?

- A glass bowl
- Salt
- Vinegar
- Paper towels
- Dirty coins (the less visible the queen is under all the dirt and muck the better)

#### FUN FACT!

You can impress your parents by using vinegar and salt to clean tea and coffee stains off mugs and cups!

### COIN CLEANER

#### PROCEDURE

1. Thoroughly stir through 1 teaspoon of salt to 1/4 cup or 60ml of vinegar.
2. Place dirty coins into bowl.
3. Wait 20 seconds and then take the coins out and rinse them in water.
4. Dry them with the paper towels.
5. Observe and record changes to the coins.
6. Experiment with citric acid (for example from oranges or lemons) and salt to see if you get the same result.

## DISCUSSION QUESTIONS:

1. What happens to the copper oxide that is removed from the coins? Try leaving some nuts and bolts in the bowl with the coins next time and observe any changes to their colour.
2. Is the acid in some citrus fruits more effective than others? What might this tell you about the level of citric acid in those fruits?
3. Observe and discuss what happens if you don't rinse the coins after you take them out of the bowl.

## WHAT HAPPENS?

A chemical change! The coins are made out of copper. Over time the copper in the coins reacts with oxygen in the air to create copper oxide and this makes the coins dull in appearance. Vinegar is an acid (acetic acid) and the salt that is stirred through the vinegar reacts with that acid which removes the copper oxide and turns back the clock on your fine piece of currency.

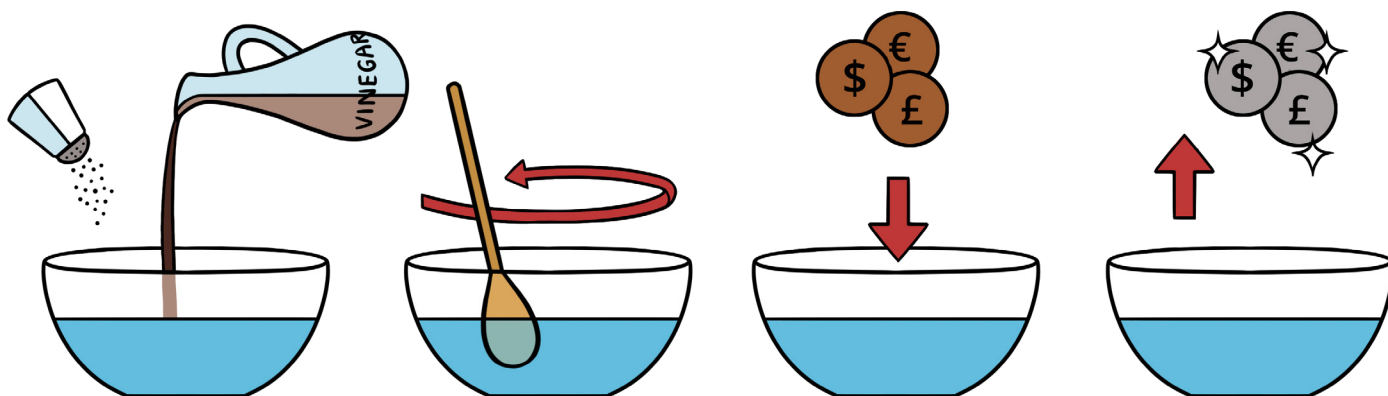

# SOAP SPEEDER TEMPLATE

Photocopy this page to make your boat. Choose your favourite boat, stick it on your foam tray or piece of cardboard and cut it out.

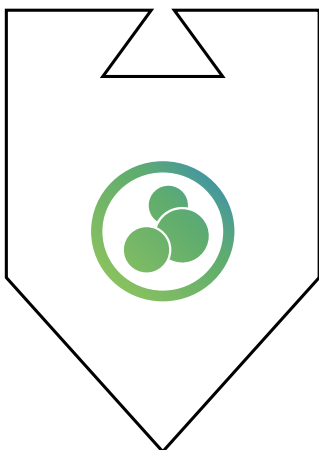
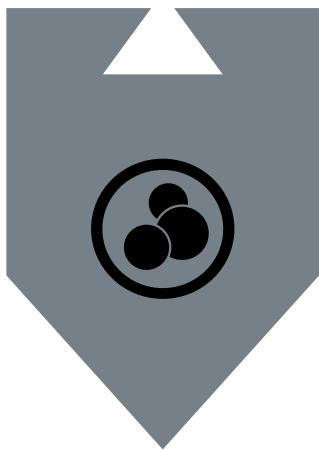
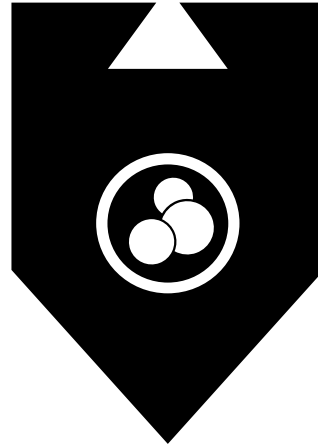
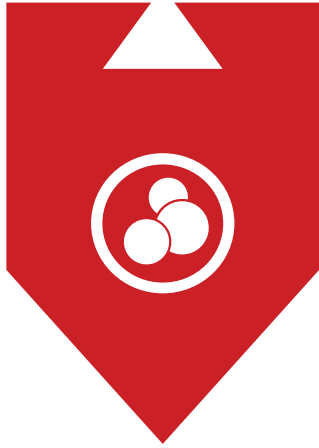



# EXPERIENCE/ LEARNING INSPIRED BY DYNAMIC CONTENT



## ENGAGING AND RELEVANT CONTENT

STEMscopes Science provides students with engaging, inquiry-based instruction that not only builds a deep understanding in science, but connects it to the real-world.

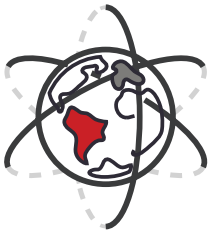

## BUILD REAL-WORLD CONNECTIONS

Through the real-world applications students can learn effortlessly, understand more, and make connections from the classroom to the real-world.

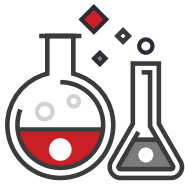

## HANDS-ON LEARNING

Research shows that hands-on learning helps students understand more, retain longer, and achieve higher test results.



## SAVE VALUABLE TIME

Spend less time planning and gathering resources. Spend more time supporting your students' learning needs.



## SIMPLE CLASSROOM INTEGRATION

The digital resources fit in with teacher instruction and, if you have existing materials, they can be used in the hands-on activities.

**TRY IT YOURSELF TODAY**

VISIT: [3P.STEMSCOPES.SCIENCE](https://3P.STEMSCOPES.SCIENCE)

**stemscopes  
SCIENCE**

 A 3P Learning product.